

## ■ PTC 热敏电阻器 PTC THERMISTOR

PTC 是指正温度系数热敏电阻，它是一种典型具有温度敏感性的半导体电阻，超过一定的温度（居里温度）时，它的电阻值随着温度的升高呈阶跃性的增高。

PTC is a positive temperature coefficient thermistor. It is a typical semiconductor resistance with temperature sensitivity. When the temperature exceeds a certain temperature (Curie temperature), its resistance value increases with the increase of temperature.

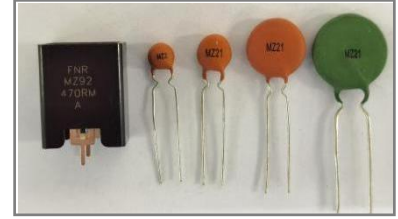

### ◆ 特性 Feature

\*  $\alpha$  系数高

High ageing coefficient

\* 体积小、耐电压强度高

Small size, Superior withstanding voltage

\* 反应速度快

Fast reaction time

\* 可靠性高、工作寿命长

High reliability, Long operating life

### ◆ 应用 Application

\* 过压、过流、过载等保护，主要用于电力变压器、各种充电器、各种仪器仪表等过流过热保护的场合

Overvoltage, overcurrent and overload protection, Mainly used for power transformers, various chargers, various instruments and other over current, overheating protection occasions

\* 电机、马达、压缩机等启动辅助

Motor, compressor startup assistance

\* 电机过热保护、电烙铁恒温维护、灯丝预热延时启动、LED 恒流补偿等多种功能

Motor overheating protection, electric iron constant temperature maintenance, filament preheating delay start, LED constant current compensation and other functions

### ◆ 安规证书 Safety Certification



UL 认证 (证书编号: E214084)

UL recognized (File# E214084)

**◆型号表示法 Part Number**

\* 包封型代码说明 Part Number Code Description Of Coating products

MZ	21	-	P	560	R	M	G	B	F	1	E	2	S
1	2	-	3	4	5	6	7	8	9	10	11	12	13

序号 NO	表示说明 Description													
1	代表风华正温度系数热敏电阻 Fenghua positive temperature coefficient thermistor													
2	类型 Type	21			3			9						
		限流型 Current-Limite			延时启动型 Delay-Time			启动类 Motor Startling						
3	居里温度 Curie temperature	M		N		P		R						
		80℃		100℃		120℃		135℃						
4	R25 电阻值代码 Resistance Value Code(R25)	2R5		5R0		560		101		102		...		
		2.5Ω		5Ω		56Ω		100Ω		1000Ω		...		
5	代表电阻 Resistance	R												
		Resistance												
6	电阻值公差 Tolerance	K		L		M		H		N		Y		
		±10%		±15%		±20%		±25%		±30%		其他 Other		
7	产品直径 Diameter of product	E	G	H	I	J	L	N	P	T				
		Φ5	Φ7	Φ8	Φ9	Φ10	Φ12	Φ14	Φ16	Φ20				
8	包装方式 Packing Method	B						T						
		散装 Bulk						编带 Tape						
9	引脚形状 Lead Style	A			F			B			C			
		直脚 Straight			内弯 Inside Kink			外弯 Outside Kink			Y型 Y Type			
10	脚距 Lead Spacing	1			2			3			4			
		5.0mm			7.5mm			10.0mm			4.0mm			
11	引脚材质 Lead Materia	E						U						
		镀锡铜包钢线 (CP 线) Tin copper clad steel lead wire						镀锡铜线 Tin plated copper wire						
12	引脚直径 Lead Diameter	1		2		3		4		7				
		Φ0.5mm		Φ0.6mm		Φ0.8mm		Φ1.0mm		Φ0.70mm				
13	引脚长度 Length of lead	S						C3.5						
		散装/长脚 Bulk/Long Lead						散装/短脚 Bulk/Short Lead						
								C3.5=3.5mm						
								C4.5=4.5mm						
						C10.0=10mm ...								

\* 外壳型代码说明 Part Number Code Description Of Casing Type

MZ	92	-	470	R	M	-	A
1	2	-	3	4	5	-	6

序号 NO	表示说明 Description						
1	代表风华正温度系数热敏电阻 Fenghua positive temperature coefficient thermistor						
2	类型 Type	92					
		外壳型启动类 Motor Startling Of Casing Type					
3	R25 电阻值代码 Resistance Value Code(R25)	5R0	330	470	560	101	...
		5Ω	33Ω	47Ω	56Ω	100Ω	...
4	代表电阻 Resistance	R					
		Resistance					
5	电阻值公差 Tolerance	K	L	M	H	N	Y
		±10%	±15%	±20%	±25%	±30%	其他 Other
6	外壳类型	A		B		C	
		A Type		B Type		C Type	

◆ 结构及尺寸 Structure And Dimensions

\* 封装型产品结构和主要材料 Construction and main materials of Coating products

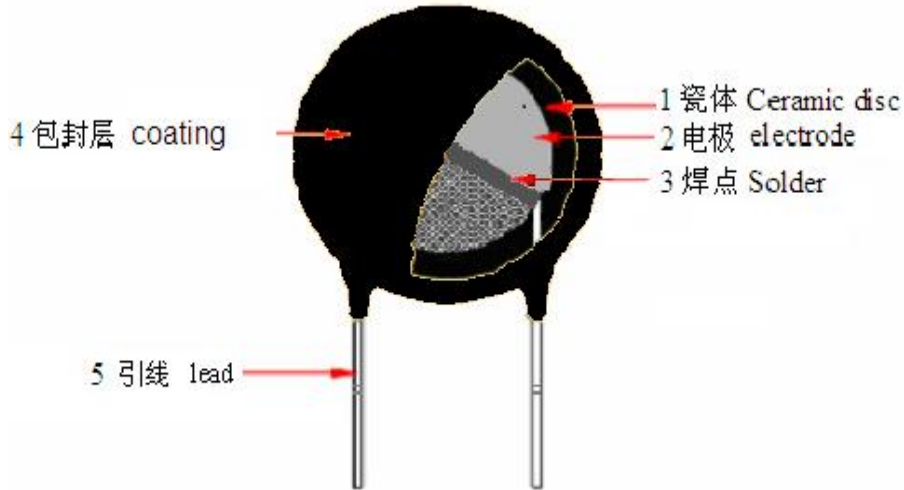

NO	主要结构 The main structure	物质成分 Material composition
1	瓷体 Ceramic disc	钛酸钡 BaTiO <sub>3</sub>
2	电极 Electrode	银、铝、镍、锌 Ag、Al、Ni、Zn
3	焊点 Solder	锡、银、铜 Sn、Ag、Cu
4	封装层 Coating	硅树脂 Silicone resin
		酚醛树脂 Phenolic resin
5	引线 Lead	镀锡引线 tinned lead

\* 外壳型产品结构和主要材料 Construction and main materials of Casing Type

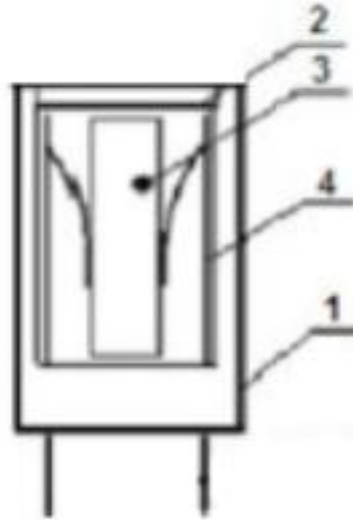

NO	主要结构 The main structure	物质成分 Material composition
1	外壳 Casing	酚醛类 (94V-0) Phenols (94V-0)
2	盖板 Cap	
3	PTC 芯片 PTC Chip	钛酸钡 BaTiO <sub>3</sub>
4	端子 Terminals	镀锡磷青铜 Tinned copper

**\* 散装包封型产品结构及尺寸 Bull Structure And Dimensions Of Coating Products**

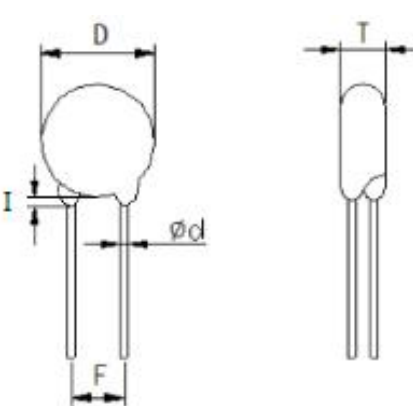
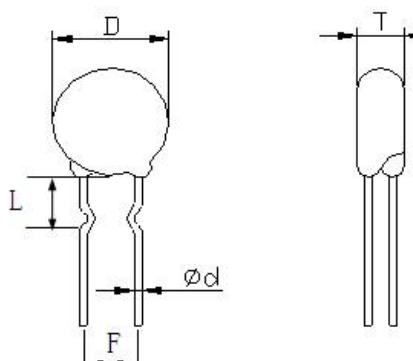
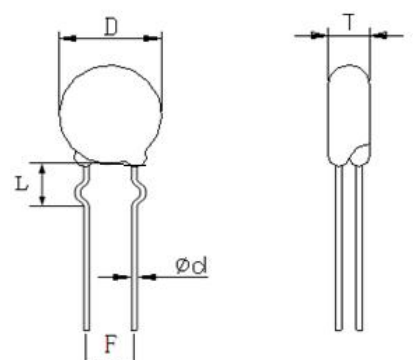
 <p>A 直脚 Straight</p>	直径型号 Type of diameter	$D_{MAX}$	F	$\phi d$	$l_{MAX}$	$T_{MAX}$
	$\Phi 5(E)$	6.5	$5.0 \pm 1.0$	$\Phi 0.6 \pm 0.05$	2.0	5.0
	$\Phi 7(G)$	8.5	$5.0 \pm 1.0$	$\Phi 0.6 \pm 0.05$	2.5	5.0
	$\Phi 8(H)$	9.5	$5.0 \pm 1.0$	$\Phi 0.6 \pm 0.05$	2.5	5.0
	$\Phi 9(I)$	10.5	$5.0 \pm 1.0$	$\Phi 0.6 \pm 0.05$	3.0	5.0
	$\Phi 10(J)$	11.5	$5.0 \pm 1.0$	$\Phi 0.6 \pm 0.05$	3.0	5.0
	$\Phi 12(L)$	14.0	$5.0 \pm 1.0$	$\Phi 0.6 \pm 0.05$	3.0	6.0
	$\Phi 14(N)$	16.0	$5.0 \pm 1.0$	$\Phi 0.6 \pm 0.05$	3.0	6.0
	$\Phi 16(P)$	18.5	$7.5 \pm 1.0$	$\Phi 0.8 \pm 0.05$	3.0	7.0
$\Phi 20(T)$	22.5	$7.5 \pm 1.0$	$\Phi 0.8 \pm 0.05$	3.5	7.0	
 <p>F 内弯 Inside Kink</p>	直径型号 Type of diameter	$D_{MAX}$	F	$\phi d$	L	$T_{MAX}$
	$\Phi 5(E)$	6.5	$5.0 \pm 1.0$	$\Phi 0.6 \pm 0.05$	$5.0 \pm 2.0$	5.0
	$\Phi 7(G)$	8.5	$5.0 \pm 1.0$	$\Phi 0.6 \pm 0.05$	$5.0 \pm 2.0$	5.0
	$\Phi 8(H)$	9.5	$5.0 \pm 1.0$	$\Phi 0.6 \pm 0.05$	$5.0 \pm 2.0$	5.0
	$\Phi 9(I)$	10.5	$5.0 \pm 1.0$	$\Phi 0.6 \pm 0.05$	$5.0 \pm 2.0$	5.0
	$\Phi 10(J)$	11.5	$5.0 \pm 1.0$	$\Phi 0.6 \pm 0.05$	$5.0 \pm 2.0$	5.0
	$\Phi 12(L)$	14.0	$5.0 \pm 1.0$	$\Phi 0.6 \pm 0.05$	$5.0 \pm 2.0$	6.0
	$\Phi 14(N)$	16.0	$5.0 \pm 1.0$	$\Phi 0.6 \pm 0.05$	$5.0 \pm 2.0$	6.0
	$\Phi 16(P)$	18.5	$7.5 \pm 1.0$	$\Phi 0.8 \pm 0.05$	$5.0 \pm 2.0$	7.0
$\Phi 20(T)$	22.5	$7.5 \pm 1.0$	$\Phi 0.8 \pm 0.05$	$5.0 \pm 2.0$	7.0	
 <p>F 外弯 Outside Kink</p>	直径型号 Type of diameter	$D_{MAX}$	F	$\phi d$	L	$T_{MAX}$
	$\Phi 5(E)$	6.5	$5.0 \pm 1.0$	$\Phi 0.6 \pm 0.05$	$5.0 \pm 2.0$	5.0
	$\Phi 7(G)$	8.5	$5.0 \pm 1.0$	$\Phi 0.6 \pm 0.05$	$5.0 \pm 2.0$	5.0
	$\Phi 8(H)$	9.5	$5.0 \pm 1.0$	$\Phi 0.6 \pm 0.05$	$5.0 \pm 2.0$	5.0
	$\Phi 9(I)$	10.5	$5.0 \pm 1.0$	$\Phi 0.6 \pm 0.05$	$5.0 \pm 2.0$	5.0
	$\Phi 10(J)$	11.5	$5.0 \pm 1.0$	$\Phi 0.6 \pm 0.05$	$5.0 \pm 2.0$	5.0
	$\Phi 12(L)$	14.0	$5.0 \pm 1.0$	$\Phi 0.6 \pm 0.05$	$5.0 \pm 2.0$	6.0
	$\Phi 14(N)$	16.0	$5.0 \pm 1.0$	$\Phi 0.6 \pm 0.05$	$5.0 \pm 2.0$	6.0
	$\Phi 16(P)$	18.5	$7.5 \pm 1.0$	$\Phi 0.8 \pm 0.05$	$5.0 \pm 2.0$	7.0
$\Phi 20(T)$	22.5	$7.5 \pm 1.0$	$\Phi 0.8 \pm 0.05$	$5.0 \pm 2.0$	7.0	

 <p>Y 型 Y Type</p>	直径型号 Type of diameter	D <sub>MAX</sub>	F	φ d	H <sub>MAX</sub>	T <sub>MAX</sub>
	Φ5(E)	6.5	5.0±1.0	Φ0.6±0.05	12.0	5.0
	Φ7(G)	8.5	5.0±1.0	Φ0.6±0.05	14.0	5.0
	Φ8(H)	9.5	5.0±1.0	Φ0.6±0.05	15.0	5.0
	Φ9(I)	10.5	5.0±1.0	Φ0.6±0.05	16.0	5.0
	Φ10(J)	11.5	5.0±1.0	Φ0.6±0.05	17.0	5.0
	Φ12(L)	14.0	5.0±1.0	Φ0.6±0.05	19.0	6.0
	Φ14(N)	16.0	5.0±1.0	Φ0.6±0.05	21.0	6.0
	Φ16(P)	18.5	7.5±1.0	Φ0.8±0.05	24.0	7.0
Φ20(T)	22.5	7.5±1.0	Φ0.8±0.05	28.0	7.0	

\* 封装型产品编带结构及尺寸 Taping Structure And Dimensions Of Coating Products

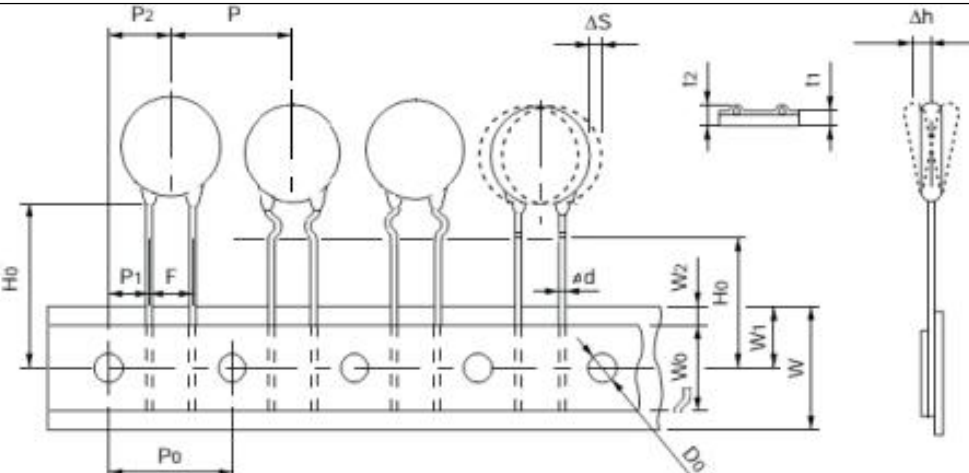
图号 Fig NO.	图示 Drawing								
A									
型号 model	符号 Symbol	P0	P1	P2	P	H0	F	d	D0
Φ5-Φ10 (F=5.0)	尺寸 Dimensions	12.7	3.85	6.35	12.7	16.0	5.0	0.6	4.0
	公差 Tolerance	±0.3	±0.7	±1.3	±1.0	±1.0	±1.0	±0.05	±0.2
	符号 Symbol	W0	W1	W2	W	ΔS	Δh	t <sub>1</sub>	t <sub>2</sub>
	尺寸 Dimensions	10.0	9.0	3	18.0	2.0	2.0	0.6	1.6
	公差 Tolerance	Min	±0.5	Max	+1.0/-0.5	Max	Max	±0.2	Max

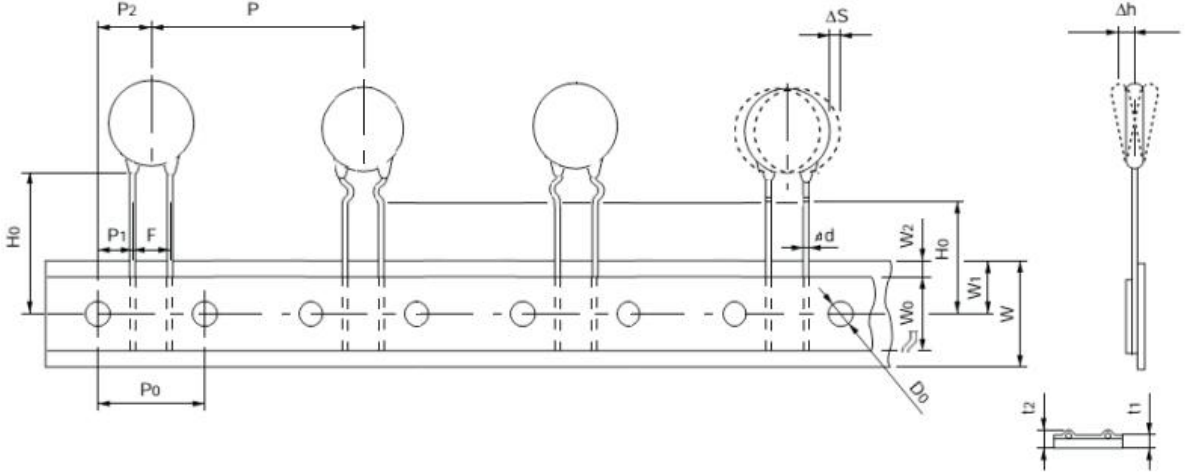
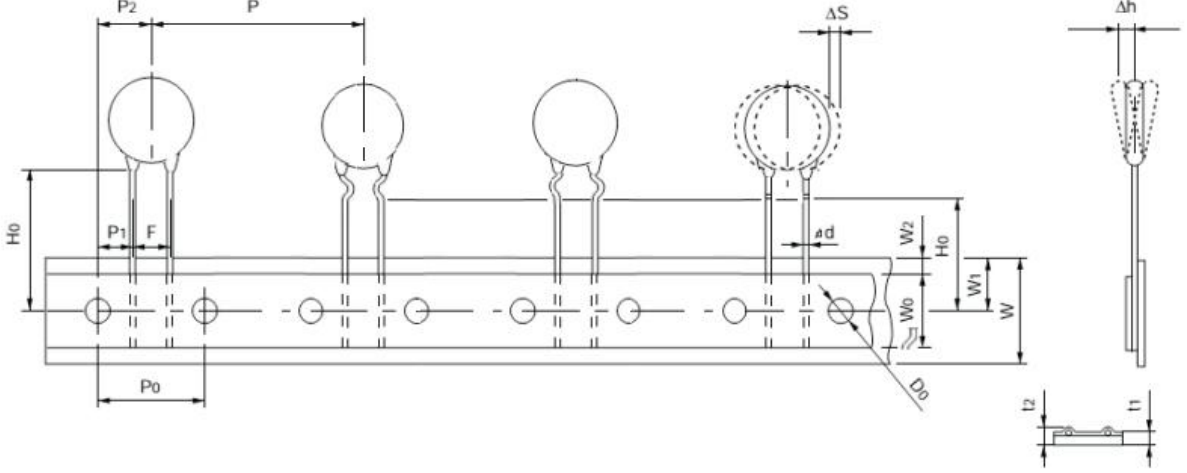
图号 Fig NO.	图示 Drawing									
B										
型号 model	符号 Symbol	P0	P1	P2	P	H0	F	d	D0	
Φ12-Φ14 (F=5.0)	尺寸 Dimensions	12.7	3.85	6.35	25.4	16.0	5.0	0.6	4.0	
	公差 Tolerance	±0.5	±0.7	±1.3	±1.0	±1.0	±1.0	±0.05	±0.2	
	符号 Symbol	W0	W1	W2	W	ΔS	ΔH	t1	t2	
	尺寸 Dimensions	12.5	9.0	3	18.0	2.0	2.0	0.6	1.6	
	公差 Tolerance	Min	±0.5	Max	+1.0/-0.5	Max	Max	±0.2	Max	
图号 Fig NO.	图示 Drawing									
C										
型号 model	符号 Symbol	P0	P1	P2	P	H0	F	d	D0	
Φ16-Φ20 (F=7.5)	尺寸 Dimensions	15.0	3.75	7.5	30.0	16.0	7.5	0.8	4.0	
	公差 Tolerance	±0.5	±0.7	±1.5	±1.0	±1.0	±1.0	±0.05	±0.2	
	符号 Symbol	W0	W1	W2	W	ΔS	Δh	t1	t2	
	尺寸 Dimensions	12.5	9.0	3	18.0	2.0	2.0	0.6	2.0	
	公差 Tolerance	Min	±0.5	Max	+1.0/-0.5	Max	Max	±0.2	Max	



\*散装外壳型产品结构及尺寸 Bull Structure And Dimensions Of Casing Type

A壳 A Type

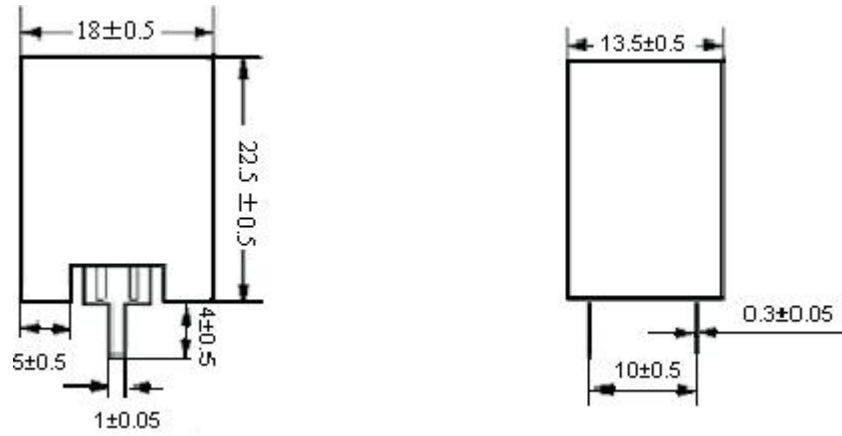

B壳 B Type

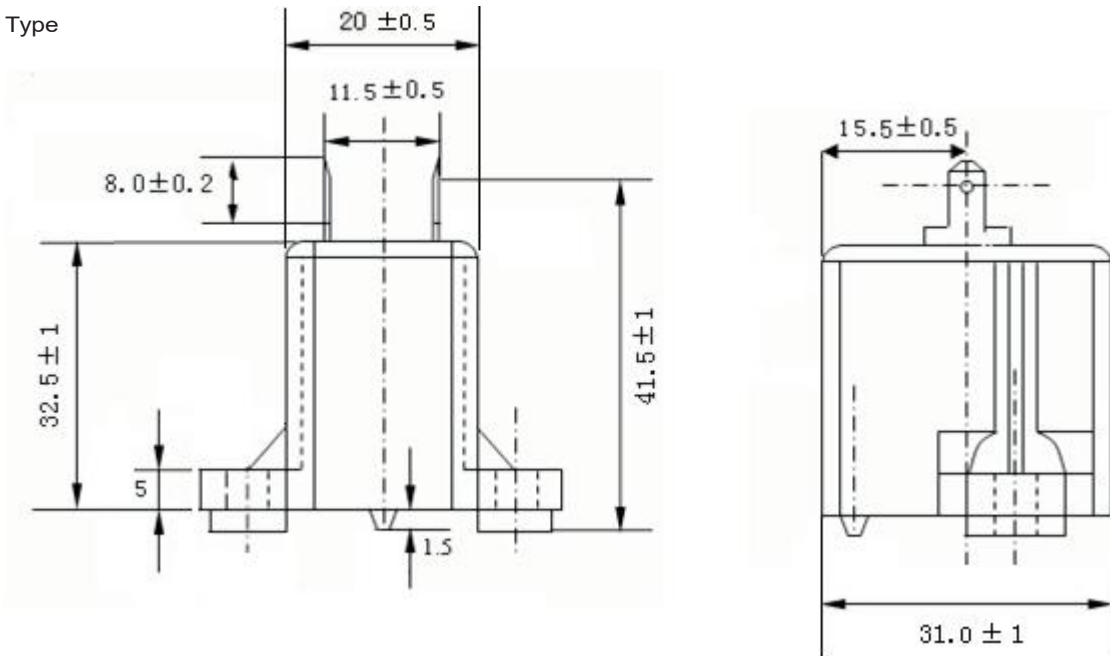

C壳 C Type

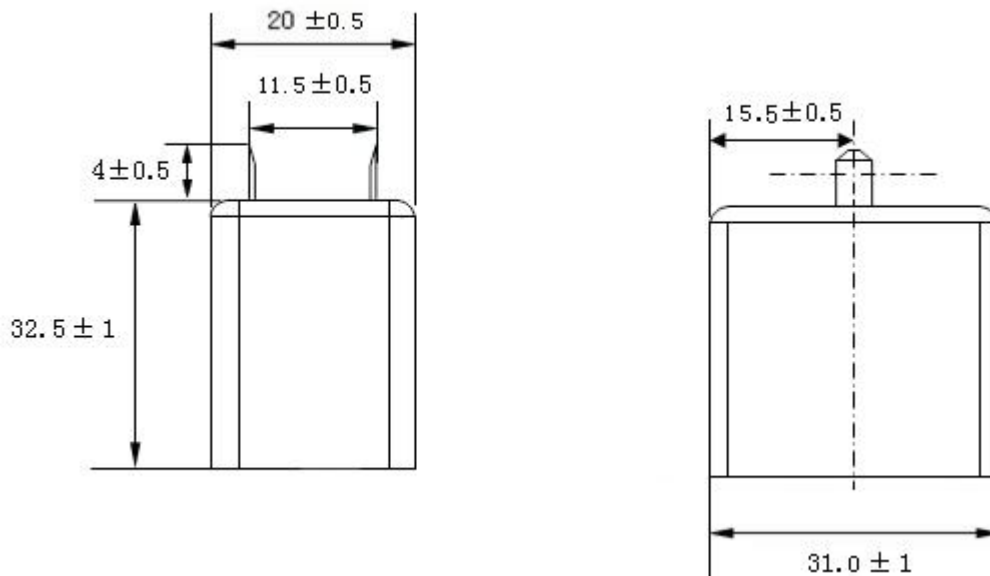

**◆ 电气性能 Performance Specification**

\*应用于变压器保护产品的技术参数

Technical parameters applied to transformer protection products

型号 Part No.	不动作电流 Non-Operating Current (mA)	动作电流 Tip current (mA)	标称电阻值 R25 Rated Resistance (Ω)	最大电压 Max Voltage (V)	典型功率 Matched Transformer (W)	直径*厚度 Diameter* Thickness (max)
MZ21-P4R7RMN	320	800	4.7	140	35	16.0*6.0
MZ21-P5R6RMN	300	750	5.6		30	16.0*6.0
*MZ21-P6R8RMN	290	725	6.8		25	16.0*6.0
MZ21-P100RML	220	510	10	270	20	14.0*6.0
*MZ21-P150RMJ	145	365	15		15	11.5*5.0
*MZ21-P200RMH	110	275	20		10	9.5*5.0
MZ21-P220RMH	140	330	22		10	9.5*5.0
MZ21-P330RMG	100	230	33		5	8.5*5.0
MZ21-P270RMN	150	360	27		20	16.0*6.0
*MZ21-P390RMI	100	250	39		15	10.5*5.0
*MZ21-P560RMG	75	190	56		10	8.5*5.0
*MZ21-P620RMG	75	180	62		10	8.5*5.0
*MZ21-P820RMG	60	150	82		10	8.5*5.0
MZ21-P121RME	35	85	120		5	6.5*5.0
MZ21-P181RME	29	70	180		3	6.5*5.0

 ①工作温度范围 Operating temperature range:  $-10^{\circ}\text{C} \sim -60^{\circ}\text{C}$ ;

②带\*型号已通过 UL 认证 Models with \* have passed UL certification;

③应用电路 Application circuit:

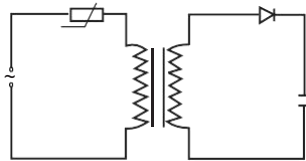

(a)用于电源变压器初级保护

Used for primary protection of power transformers

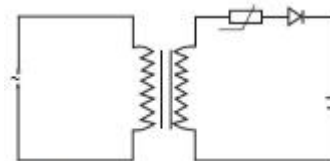

(b)用于电源变压器次级保护

Secondary protection for power transformer

\*用于通讯设备保护产品的技术参数

Technical parameters of protection products for communication equipment

型号规格 Part No.	标称电阻值 R25 Rated Resistance (Ω)	不动作 电流 Non-Oper ating Current (mA)	响应时间 Responding Time (S)			最大电压 Max Voltage (V)	耐电流 Current withstand(time)		直径*厚度 Diameter* Thickness (max)
			3A→ 0.5A	1A→ 0.5A	0.5A→ 0.15A		最大电流 Max Current (A)	工频电流 (次数) Power Frequenc y curren (time)	
MZ21-M120RMG	12	100	0.45	4	25	250	0.8	20	8.5*5.0
*MZ21-M180RMG	18	90	0.35	2	10	250	0.8	20	8.5*5.0
*MZ21-M200RMG	20	85	0.35	2	10	250	0.8	20	8.5*5.0
MZ21-M250RMG	25	75	0.3	1.5	10	300	0.8	20	8.5*5.0
*MZ21-M300RMG	30	65	0.3	1.5	10	300	0.8	20	8.5*5.0
*MZ21-M450RMG	45	50	0.15	0.65	3	300	0.6	20	8.5*5.0
*MZ21-M560RMG	56	45	0.15	0.65	3	300	0.6	20	8.5*5.0
*MZ21-M620RMG	62	45	0.12	0.6	3	420	0.6	20	8.5*5.0
*MZ21-M700RMG	70	40	0.12	0.6	3	420	0.6	20	8.5*5.0
*MZ21-M820RMG	82	35	0.1	0.6	3	420	0.6	20	8.5*5.0
*MZ21-M101RMG	100	35	0.1	0.6	3	420	0.5	20	8.5*5.0
MZ21-N120RMG	12	110	0.8	8	30	250	0.8	20	8.5*5.0
*MZ21-N180RMG	18	100	0.4	2.5	10	250	0.8	20	8.5*5.0
*MZ21-N200RMG	20	95	0.4	2.5	10	250	0.8	20	8.5*5.0
MZ21-N250RMG	25	85	0.35	2	10	300	0.8	20	8.5*5.0
*MZ21-N300RMG	30	80	0.35	2	10	300	0.8	20	8.5*5.0
*MZ21-N450RMG	45	70	0.3	1	4	300	0.6	20	8.5*5.0
*MZ21-N560RMG	56	65	0.15	0.8	3.5	300	0.6	20	8.5*5.0
*MZ21-N620RMG	62	60	0.15	0.8	3.5	420	0.6	20	8.5*5.0
*MZ21-N700RMG	70	55	0.15	0.8	3.5	420	0.6	20	8.5*5.0
*MZ21-N820RMG	82	50	0.12	0.6	3	420	0.6	20	8.5*5.0
*MZ21-N101RMG	100	45	0.12	0.6	3	420	0.5	20	8.5*5.0
MZ21-M180RMH	18	95	0.4	2.5	10	250	0.8	20	9.5*5.0
*MZ21-M200RMH	20	90	0.4	2.5	10	250	0.8	20	9.5*5.0
*MZ21-M250RMH	25	80	0.35	2	10	300	0.8	20	9.5*5.0
*MZ21-M300RMH	30	70	0.35	2	10	300	0.8	20	9.5*5.0
*MZ21-M450RMH	45	60	0.3	1	4	300	0.8	20	9.5*5.0
*MZ21-M500RMH	50	60	0.3	1	4	300	0.6	20	9.5*5.0
MZ21-N180RMH	18	105	0.4	2.5	10	250	0.8	20	9.5*5.0
*MZ21-N200RMH	20	100	0.4	2.5	10	250	0.8	20	9.5*5.0
*MZ21-N250RMH	25	90	0.35	2	10	300	0.8	20	9.5*5.0
*MZ21-N300RMH	30	85	0.35	2	10	300	0.8	20	9.5*5.0

型号规格 Part No.	标称电阻 值 R25 Rated Resistanc e ( Ω )	不动作电 流 Non-Oper ating Current (mA)	响应时间 Responding Time (S)			最大电压 Max Voitage (V)	耐电流 Current withstand(time)		直径*厚度 Diameter* Thickness (max)
			3A→ 0.5A	1A→ 0.5A	0.5A→ 0.15A		最大电流 Max Current (A)	工频电流 (次数) Power Frequency curren (time)	
MZ21-M180RMI	18	100	0.4	2.5	10	250	0.8	20	10.5*5.0
*MZ21-M200RMI	20	95	0.4	2.5	10	250	0.8	20	10.5*5.0
*MZ21-M250RMI	25	85	0.35	2	10	300	0.8	20	10.5*5.0
*MZ21-M300RMI	30	75	0.35	2	10	300	0.8	20	10.5*5.0
*MZ21-M390RMI	39	70	0.3	1	4	300	0.8	20	10.5*5.0
*MZ21-M500RMI	50	65	0.12	0.6	3	300	0.6	20	10.5*5.0
*MZ21-M550RMI	55	60	0.12	0.6	3	300	0.6	20	10.5*5.0
*MZ21-N180RMI	18	115	0.4	2.5	10	250	0.8	20	10.5*5.0
*MZ21-N200RMI	20	110	0.4	2.5	10	250	0.8	20	10.5*5.0
*MZ21-N250RMI	25	95	0.35	2	10	300	0.8	20	10.5*5.0
*MZ21-N300RMI	30	90	0.35	2	10	300	0.8	20	10.5*5.0
*MZ21-N390RMI	39	85	0.3	1	4	300	0.8	20	10.5*5.0
*MZ21-N500RMI	50	80	0.15	0.8	3.5	300	0.6	20	10.5*5.0
*MZ21-M8R0RMJ	8	125	0.8	8	35	250	0.8	20	11.5*5.0
*MZ21-M120RMJ	12	115	0.8	8	35	250	0.8	20	11.5*5.0
*MZ21-N8R0RMJ	8	150	0.8	8	35	250	0.8	20	11.5*5.0
*MZ21-N120RMJ	12	135	0.8	8	35	250	0.8	20	11.5*5.0

①工作温度范围 Operating temperature range: -10℃~-60℃;

②可按客户特殊要求设计产品 Products can be designed according to special requirements of customers;

③以上系列冲击电流试验条件: 波形 10/1000μs, 25A, 30 次或者 30A 10 次 Shock current test conditions of above models: waveform 10/1000μs, 25A, 30 times or 30A 10 times;

④带\*型号已通过 UL 认证 Models with \* have passed UL certification;

⑤应用电路 Application circuit:

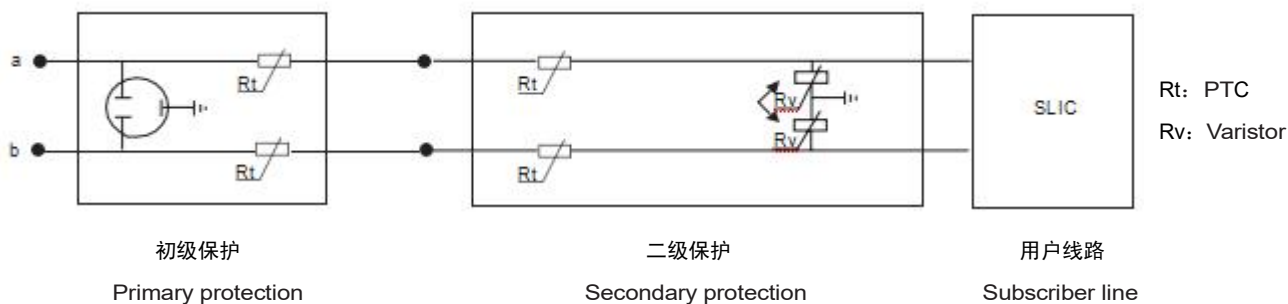

\*用于电源和一般电路保护产品的技术参数

Technical parameters of products used to protect power supply and general circuits

型号规格 Part No.	不动作电流 Non- Operating Current (mA)	动作电流 Tip Current (mA)	标称电阻 R25 Rated Resistance ( $\Omega$ )	开关温度 Switching Temperature ( $^{\circ}\text{C}$ )	最大电压 Max Valtage (V)	直径*厚度 Diameter* Thickness (max)
*MZ21-M151RME	20	50	150	80	270	6.5*5.0
*MZ21-M101RMG	35	90	100		270	8.5*5.0
MZ21-M500RMG	50	125	50		270	8.5*5.0
MZ21-M100RMG	130	260	10		270	8.5*5.0
*MZ21-M150RMJ	110	275	15		270	11.5*5.0
*MZ21-M100RMN	150	375	10		220	16.0*6.0
*MZ21-N151RME	30	75	150	100	270	6.5*5.0
*MZ21-N101RME	35	90	100		270	6.5*5.0
*MZ21-N820RMG	50	125	82		270	8.5*5.0
MZ21-N150RML	150	300	15		270	14.0*6.0
*MZ21-N100RMN	180	450	10		220	16.0*6.0
*MZ21-N8R0RMN	190	470	8		220	16.0*6.0

①工作温度范围 Operating temperature range:  $-10^{\circ}\text{C}\sim-60^{\circ}\text{C}$ ;

②可按客户特殊要求设计产品 Products can be designed according to special requirements of customers;

③带\*型号已通过 UL 认证 Models with \* have passed UL certification;

④应用电路 Application circuit:

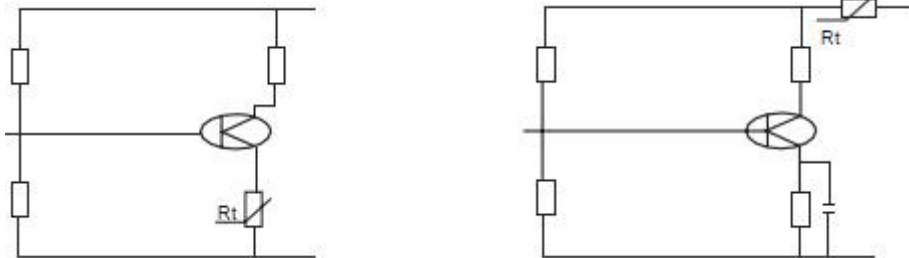

晶体管电路 transistor circuit

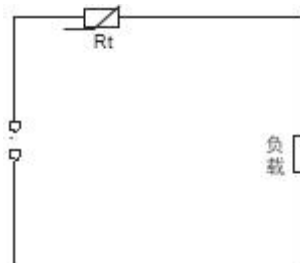

一般电路回路 General circuit circuit

\*用于过流保护产品的技术参数

Technical parameters for overcurrent protection products

型号规格 Part No.	标称电阻值 R25 Rated Resistance ( $\Omega$ )	不动作电流 Non- Operating Current (mA)	动作电流 Tip Current (mA)	开关温度 Switching Temperature ( $^{\circ}\text{C}$ )	最大电压 Max Voltage (V)	直径*厚度 Diameter* Thickness (max)
MZ21-M400RME	40	45	115	80	220	6.5*5.0
MZ21-N400RME	40	60	150	100	220	6.5*5.0
MZ21-P400RME	40	70	175	120	220	6.5*5.0
MZ21-M101RME	100	25	65	80	270	6.5*5.0
MZ21-N101RME	100	35	90	100	270	6.5*5.0
MZ21-P101RME	100	40	100	120	270	6.5*5.0
MZ21-M151RME	150	20	50	80	270	6.5*5.0
MZ21-N151RME	150	30	75	100	270	6.5*5.0
MZ21-P151RME	150	35	90	120	270	6.5*5.0
MZ21-M471RME	470	12	30	80	270	6.5*5.0
MZ21-N471RME	470	18	45	100	270	6.5*5.0
MZ21-P471RME	470	20	50	120	270	6.5*5.0
MZ21-M501RME	500	12	30	80	270	6.5*5.0
MZ21-N501RME	500	18	45	100	270	6.5*5.0
MZ21-P501RME	500	20	50	120	270	6.5*5.0
MZ21-M601RME	600	10	25	80	270	6.5*5.0
MZ21-N601RME	600	15	40	100	270	6.5*5.0
MZ21-P601RME	600	18	45	120	270	6.5*5.0
MZ21-M681RME	680	10	25	80	270	6.5*5.0
MZ21-N681RME	680	15	40	100	270	6.5*5.0
MZ21-P681RME	680	18	45	120	270	6.5*5.0
MZ21-M102RME	1000	8	20	80	270	6.5*5.0
MZ21-N102RME	1000	12	30	100	270	6.5*5.0
MZ21-P102RME	1000	15	40	120	270	6.5*5.0
MZ21-M180RMG	18	90	225	80	220	8.5*5.0
MZ21-N180RMG	18	100	250	100	220	8.5*5.0
MZ21-P180RMG	18	110	275	120	220	8.5*5.0
MZ21-M200RMG	20	85	215	80	220	8.5*5.0
MZ21-N200RMG	20	95	240	100	220	8.5*5.0
MZ21-P200RMG	20	100	275	120	220	8.5*5.0
MZ21-M300RMG	30	65	165	80	270	8.5*5.0
MZ21-N300RMG	30	80	200	100	270	8.5*5.0
MZ21-P300RMG	30	90	225	120	270	8.5*5.0
MZ21-M450RMG	45	50	125	80	270	8.5*5.0
MZ21-N450RMG	45	70	175	100	270	8.5*5.0

型号规格 Part No.	标称电阻值 R25 Rated Resistance ( $\Omega$ )	不动作电流 Non- Operating Current (mA)	动作电流 Tip Current (mA)	开关温度 Switching Temperature ( $^{\circ}\text{C}$ )	最大电压 Max Valtage (V)	直径*厚度 Diameter* Thickness (max)
MZ21-P450RMG	45	80	200	120	270	8.5*5.0
MZ21-M560RMG	56	45	115	80	270	8.5*5.0
MZ21-N560RMG	56	65	165	100	270	8.5*5.0
MZ21-P560RMG	56	75	190	120	270	8.5*5.0
MZ21-M620RMG	62	45	115	80	270	8.5*5.0
MZ21-N620RMG	62	60	150	100	270	8.5*5.0
MZ21-P620RMG	62	75	180	120	270	8.5*5.0
MZ21-M700RMG	70	40	100	80	270	8.5*5.0
MZ21-N700RMG	70	55	140	100	270	8.5*5.0
MZ21-P700RMG	70	60	150	120	270	8.5*5.0
MZ21-M820RMG	82	35	90	80	270	8.5*5.0
MZ21-N820RMG	82	50	125	100	270	8.5*5.0
MZ21-P820RMG	82	60	150	120	270	8.5*5.0
MZ21-M101RMG	100	35	90	80	270	8.5*5.0
MZ21-N101RMG	100	45	115	100	270	8.5*5.0
MZ21-P101RMG	100	50	125	120	270	8.5*5.0
MZ21-M151RMG	150	30	75	80	270	8.5*5.0
MZ21-N151RMG	150	35	90	100	270	8.5*5.0
MZ21-P151RMG	150	43	86	120	270	8.5*5.0
MZ21-M221RMG	220	25	65	80	270	8.5*5.0
MZ21-N221RMG	220	30	75	100	270	8.5*5.0
MZ21-P221RMG	220	35	90	120	270	8.5*5.0
MZ21-M331RMG	330	20	50	80	270	8.5*5.0
MZ21-N331RMG	330	25	65	100	270	8.5*5.0
MZ21-P331RMG	330	30	75	120	270	8.5*5.0
MZ21-M471RMG	470	18	45	80	270	8.5*5.0
MZ21-N471RMG	470	20	50	100	270	8.5*5.0
MZ21-P471RMG	470	25	65	120	270	8.5*5.0
MZ21-M501RMG	500	18	45	80	270	8.5*5.0
MZ21-N501RMG	500	20	50	100	270	8.5*5.0
MZ21-P501RMG	500	25	65	120	270	8.5*5.0
MZ21-M601RMG	500	15	40	80	270	8.5*5.0
MZ21-N601RMG	600	18	45	100	270	8.5*5.0
MZ21-P601RMG	600	20	50	120	270	8.5*5.0
MZ21-M681RMG	600	15	40	80	270	8.5*5.0
MZ21-N681RMG	680	18	45	100	270	8.5*5.0
MZ21-P681RMG	680	20	50	120	270	8.5*5.0
MZ21-M102RMG	1000	12	30	80	270	8.5*5.0

型号规格 Part No.	标称电阻值 R25 Rated Resistance ( $\Omega$ )	不动作电流 Non- Operating Current (mA)	动作电流 Tip Current (mA)	开关温度 Switching Temperature ( $^{\circ}\text{C}$ )	最大电压 Max Valtage (V)	直径*厚度 Diameter* Thickness (max)
MZ21-N102RMG	1000	14	35	100	270	8.5*5.0
MZ21-P102RMG	1000	17	45	120	270	8.5*5.0
MZ21-P202RYG	2000	15	40	120	270	8.5*5.0
MZ21-M200RMH	20	90	225	80	220	9.5*5.0
MZ21-N200RMH	20	100	250	100	220	9.5*5.0
MZ21-P200RMH	20	110	275	120	220	9.5*5.0
MZ21-M250RMH	25	80	200	80	270	9.5*5.0
MZ21-N250RMH	25	90	225	100	270	9.5*5.0
MZ21-P250RMH	25	100	250	120	270	9.5*5.0
MZ21-M300RMH	30	70	175	80	270	9.5*5.0
MZ21-N300RMH	30	85	215	100	270	9.5*5.0
MZ21-P300RMH	30	95	240	120	270	9.5*5.0
MZ21-M450RMH	45	60	150	80	270	9.5*5.0
MZ21-N450RMH	45	75	190	100	270	9.5*5.0
MZ21-P450RMH	45	85	215	120	270	9.5*5.0
MZ21-M500RMH	50	60	120	80	270	9.5*5.0
MZ21-N500RMH	50	70	175	100	270	9.5*5.0
MZ21-P500RMH	50	80	200	120	270	9.5*5.0
MZ21-M221RMH	220	30	75	80	270	9.5*5.0
MZ21-N221RMH	220	25	65	80	270	9.5*5.0
MZ21-M451RMH	450	20	50	80	270	9.5*5.0
MZ21-M200RMI	20	95	240	80	220	10.5*5.0
MZ21-N200RMI	20	110	275	100	220	10.5*5.0
MZ21-P200RMI	20	120	300	120	220	10.5*5.0
MZ21-M250RMI	25	85	215	80	270	10.5*5.0
MZ21-N250RMI	25	95	240	100	270	10.5*5.0
MZ21-P250RMI	25	100	250	120	270	10.5*5.0
MZ21-M300RMI	30	75	190	80	270	10.5*5.0
MZ21-N300RMI	30	90	225	100	270	10.5*5.0
MZ21-P300RMI	30	100	250	120	270	10.5*5.0
MZ21-M390RMI	39	70	175	80	270	10.5*5.0
MZ21-N390RMI	39	85	215	100	270	10.5*5.0
MZ21-P390RMI	39	100	250	120	270	10.5*5.0
MZ21-M450RMI	45	65	165	80	270	10.5*5.0
MZ21-N450RMI	45	80	200	100	270	10.5*5.0
MZ21-P450RMI	45	90	225	120	270	10.5*5.0
MZ21-M500RMI	50	65	165	80	270	10.5*5.0
MZ21-N500RMI	50	80	200	80	270	10.5*5.0



型号规格 Part No.	标称电阻值 R25 Rated Resistance ( $\Omega$ )	不动作电流 Non- Operating Current (mA)	动作电流 Tip Current (mA)	开关温度 Switching Temperature ( $^{\circ}\text{C}$ )	最大电压 Max Valtage (V)	直径*厚度 Diameter* Thickness (max)
MZ21-P500RMI	50	85	215	80	270	10.5*5.0
MZ21-M351RMI	350	30	75	80	270	10.5*5.0
MZ21-M8R0RMJ	8	125	315	80	220	11.5*5.0
MZ21-N8R0RMJ	8	150	375	100	220	11.5*5.0
MZ21-P8R0RMJ	8	160	400	120	220	11.5*5.0
MZ21-M100RMJ	10	120	300	80	220	11.5*5.0
MZ21-N100RMJ	10	145	365	100	220	11.5*5.0
MZ21-P100RMJ	10	155	390	120	220	11.5*5.0
MZ21-M120RMJ	12	115	290	80	220	11.5*5.0
MZ21-N120RMJ	12	135	340	100	220	11.5*5.0
MZ21-P120RMJ	12	150	375	120	220	11.5*5.0
MZ21-M150RMJ	15	110	275	80	270	11.5*5.0
MZ21-N150RMJ	15	130	325	100	270	11.5*5.0
MZ21-P150RMJ	15	145	365	120	270	11.5*5.0
MZ21-M200RMJ	20	100	250	80	270	11.5*5.0
MZ21-N200RMJ	20	120	300	100	270	11.5*5.0
MZ21-P200RMJ	20	135	340	120	270	11.5*5.0
MZ21-M250RMJ	25	90	225	80	270	11.5*5.0
MZ21-N250RMJ	25	105	265	100	270	11.5*5.0
MZ21-P250RMJ	25	120	300	120	270	11.5*5.0
MZ21-M6R8RMN	6.8	170	425	80	220	16.0*6.0
MZ21-N6R8RMN	6.8	200	500	100	220	16.0*6.0
MZ21-P6R8RMN	6.8	290	725	120	220	16.0*6.0
MZ21-M8R0RMN	8	160	400	80	220	16.0*6.0
MZ21-N8R0RMN	8	190	475	100	220	16.0*6.0
MZ21-P8R0RMN	8	260	650	120	220	16.0*6.0
MZ21-M100RMN	10	150	375	80	220	16.0*6.0
MZ21-N100RMN	10	180	450	100	220	16.0*6.0
MZ21-P100RMN	10	240	600	120	220	16.0*6.0
MZ21-M120RMN	12	140	350	80	220	16.0*6.0
MZ21-N120RMN	12	170	425	100	220	16.0*6.0
MZ21-P120RMN	12	200	500	120	220	16.0*6.0
MZ21-M150RMN	15	130	325	80	270	16.0*6.0
MZ21-N150RMN	15	160	400	100	270	16.0*6.0
MZ21-P150RMN	15	180	450	120	270	16.0*6.0

以上型号已通过 UL 和 CUL 认证 Models have passed UL and CUL certification

**\*MZ3 型热敏电阻的技术参数 The technical parameters of MZ3 thermistor**

型号规格 Part No.	开关温度 Switching Temperature ( $^{\circ}\text{C}$ )	标称电阻值 R25 Rated Resistance ( $\Omega$ )	耐电压 Breakdown Voltage (V)	直径*厚度 Diameter*Thicknes (max)
*MZ3-M101RME	80	100	500	6.5*5.0
*MZ3-M151RME	80	150	500	6.5*5.0
MZ3-M201RME	80	200	600	6.5*5.0
*MZ3-M221RME	80	220	600	6.5*5.0
MZ3-M301RME	80	300	600	6.5*5.0
*MZ3-M331RME	80	330	600	6.5*5.0
*MZ3-M471RME	80	470	600	6.5*5.0
*MZ3-M501RME	80	500	600	6.5*5.0
*MZ3-M601RME	80	600	600	6.5*5.0
*MZ3-M681RME	80	680	600	6.5*5.0
MZ3-M801RME	80	800	600	6.5*5.0
*MZ3-M102RME	80	1000	600	6.5*5.0
*MZ3-M101RMG	80	100	500	8.5*5.0
*MZ3-M151RMG	80	150	600	8.5*5.0
MZ3-M201RMG	80	200	600	8.5*5.0
*MZ3-M221RMG	80	220	600	8.5*5.0
MZ3-M301RMG	80	300	600	8.5*5.0
*MZ3-M331RMG	80	330	600	8.5*5.0
*MZ3-M471RMG	80	470	600	8.5*5.0
*MZ3-M501RMG	80	500	600	8.5*5.0
*MZ3-M601RMG	80	600	600	8.5*5.0
*MZ3-M681RMG	80	680	600	8.5*5.0
MZ3-M801RMG	80	800	750	8.5*5.0
*MZ3-M102RMG	80	1000	750	8.5*5.0
*MZ3-N101RME	100	100	420	6.5*5.0
MZ3-N151RME	100	150	500	6.5*5.0
MZ3-N201RME	100	200	600	6.5*5.0
*MZ3-N221RME	100	220	600	6.5*5.0
MZ3-N301RME	100	300	600	6.5*5.0
*MZ3-N331RME	100	330	600	6.5*5.0
*MZ3-N471RME	100	470	600	6.5*5.0
*MZ3-N501RME	100	500	600	6.5*5.0
*MZ3-N601RME	100	600	600	6.5*5.0
*MZ3-N681RME	100	680	600	6.5*5.0
MZ3-N801RME	100	800	600	6.5*5.0
*MZ3-N102RME	100	1000	600	6.5*5.0
*MZ3-N101RMG	100	100	600	8.5*5.0

型号规格 Part No.	开关温度 Switching Temperature ( °C )	标称电阻值 R25 Rated Resistance ( Ω )	耐电压 Breakdown Voltage (V)	直径*厚度 Diameter*Thicknes ( max )
*MZ3-N151RMG	100	150	600	8.5*5.0
MZ3-N201RMG	100	200	600	8.5*5.0
*MZ3-N221RMG	100	220	600	8.5*5.0
MZ3-N301RMG	100	300	600	8.5*5.0
*MZ3-N331RMG	100	330	600	8.5*5.0
*MZ3-N471RMG	100	470	600	8.5*5.0
*MZ3-N501RMG	100	500	600	8.5*5.0
*MZ3-N601RMG	100	600	600	8.5*5.0
*MZ3-N681RMG	100	680	600	8.5*5.0
MZ3-N801RMG	100	800	600	8.5*5.0
*MZ3-N102RMG	100	1000	750	8.5*5.0
*MZ3-P101RME	120	100	420	6.5*5.0
MZ3-P151RME	120	150	500	6.5*5.0
MZ3-P201RME	120	200	600	6.5*5.0
*MZ3-P221RME	120	220	600	6.5*5.0
MZ3-P301RME	120	300	600	6.5*5.0
*MZ3-P331RME	120	330	600	6.5*5.0
*MZ3-P471RME	120	470	600	6.5*5.0
*MZ3-P501RME	120	500	600	6.5*5.0
*MZ3-P601RME	120	600	600	6.5*5.0
*MZ3-P681RME	120	680	600	6.5*5.0
MZ3-P801RME	120	800	600	6.5*5.0
*MZ3-P102RME	120	1000	600	6.5*5.0
*MZ3-P101RMG	120	100	420	8.5*5.0
*MZ3-P151RMG	120	150	500	8.5*5.0
MZ3-P201RMG	120	200	600	8.5*5.0
*MZ3-P221RMG	120	220	600	8.5*5.0
MZ3-P301RMG	120	300	600	8.5*5.0
*MZ3-P331RMG	120	330	600	8.5*5.0
*MZ3-P471RMG	120	470	600	8.5*5.0
*MZ3-P501RMG	120	500	600	8.5*5.0
*MZ3-P601RMG	120	600	600	8.5*5.0
*MZ3-P681RMG	120	680	600	8.5*5.0
MZ3-P801RMG	120	800	600	8.5*5.0
*MZ3-P102RMG	120	1000	750	8.5*5.0
*MZ3-P202RYG	120	2000	900	8.5*5.0
*MZ3-M221RMH	80	220	600	9.5*5.0
*MZ3-M251RMH	80	250	600	9.5*5.0

型号规格 Part No.	开关温度 Switching Temperature ( °C )	标称电阻值 R25 Rated Resistance ( Ω )	耐电压 Breakdown Voltage (V)	直径*厚度 Diameter*Thicknes ( max )
*MZ3-M451RMH	80	450	600	9.5*5.0
*MZ3-M351RMI	80	350	600	10.5*5.0

①工作温度范围 Operating temperature range:  $-10^{\circ}\text{C}\sim-125^{\circ}\text{C}$ ;

②可按客户特殊要求设计产品 Products can be designed according to special requirements of customers;

③带\*型号已通过 UL 认证 Models with \* have passed UL certification;

④应用电路 Application circuit:

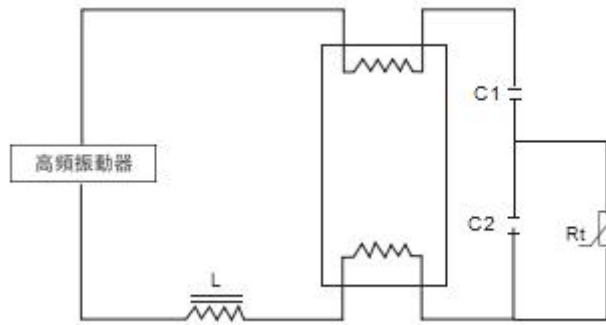

**\*外壳型启动类产品技术参数 The technical parameters of startling casing type**

型号规格 Part No.	标称电阻值 R25 Rated Resistance (Ω)	开关温度 Switching Temperature (℃)	额定电压 Rated voltage (Vac)	最大电压 Max Voltage (Vac)	最大功率 Max Power (W)	最大电流 Max Current (A)	启动时间 Time to Tip (S)	恢复时间 Recover Time (S)
MZ92-330R□-A	33	125	220	250	2.3	6	0.1-0.5	80
MZ92-400R□-A	40	125	220	250	2.3	6	0.1-0.5	80
MZ92-470R□-A	47	125	220	276	3.5	8	0.1-0.5	80
MZ92-820R□-A	82	125	220	276	3.5	6	0.1-0.5	80
MZ92-101R□-A	100	125	220	380	3.5	4	0.1-0.5	90
MZ92-201R□-A	200	125	220	380	3.5	3	0.1-0.5	90
MZ92-330R□-B	33	125	220	355	4	7	1.0-4.0	90
MZ92-400R□-B	40	125	220	380	4	12	1.0-4.0	90
MZ92-500R□-B	50	125	380	450	4	12	1.0-4.0	90
MZ92-101R□-B	100	125	220	500	4	5	0.2-2.0	85
MZ92-330R□-C	33	125	220	355	4	7	1.0-4.0	90
MZ92-400R□-C	40	125	220	380	4	12	1.0-4.0	90
MZ92-500R□-C	50	125	380	450	4	12	1.0-4.0	90
MZ92-101R□-C	100	125	220	500	4	5	0.2-2.0	85

①“□”代表公差 K: ±10%, L: ±15%, M: ±20%, H: ±25%, N: ±30%, Y: 其他 “□”Represents tolerance K: ±10%, L: ±15%, M: ±20%, H: ±25%, N: ±30%, Y: other;

②以上型号已通过 UL 和 CQC 认证 Models have passed UL and CQC certification;

③④应用电路 Application circuit:

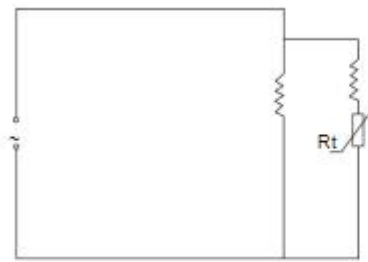

用于分相电路 Polyphase circuit

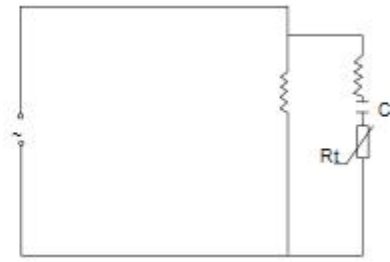

用于电容式电机电路 Capacitive motor circuit

**◆可靠性测试方法 Reliability Test Method**

\*一般包封型产品测试 General coating products test

项目 Item	测试条件/测试方法 Method of test	性能要求 Specification request
可焊性 Solderability	根据 GB2423.28 试验 Ta 进行试验，采用焊槽法，将引出端沾助焊剂后，浸入到温度为 $245\pm 5^{\circ}\text{C}$ 、深度为 15 mm 的锡槽中锡面距 PTC 本体下端 5 mm 处，持续 3~5 秒。 Dipping the PTC terminals to a depth of 15mm in a soldering bath of $245\pm 5^{\circ}\text{C}$ and to the place of 5 mm far from PTC body for 3~5s (See IEC68-2-20/GB2423.28 Ta)	95%以上的焊接面被上焊锡 Min.95% terminal covered
耐焊接热 Resistance to soldering heat	根据 IEC68-2-20/GB2423.28 试验 Tb 进行试验。 将端子浸入 $260\pm 5^{\circ}\text{C}$ 的焊接槽中 15mm 深，深度距离 PTC 本体 2-2.5 mm 处浸泡 $10\pm 0.5$ s，在常温常湿条件下恢复 4-5 小时后，测试零功率电阻。 Dipping the terminals to a depth of 15 mm in a soldering bath of $260\pm 5^{\circ}\text{C}$ and to the place of 2-2.5 mm far from PTC body for $10\pm 0.5$ s. After recovering for 4-5 hours under normal temperature. The resistance shall be measured. (See IEC68-2-20/GB2423.28 Tb)	$\Delta R/R \leq 10\%$ 无机械损伤 No substantial damage
引出端强度 Strength of lead terminal	根据 IEC68-2-21/GB2423.29 试验 U 进行试验。 试验 Ua: 拉力 10 N，持续 10 S； 试验 Ub: 弯曲 $90^{\circ}$ ，拉力 5 N，连续两次； 试验 Uc: 扭转 $180^{\circ}$ ，连续两次。 在常温常湿条件下恢复 4-5 小时后，复测零功率电阻。 Fasten the body and apply a force gradually to each lead until 10N and then keep for 10sec, hold the body and apply a force to each lead until $90^{\circ}$ slowly at 5 N in the direction of lead axis and then keep for 10 sec. And do this in the opposite direction repeat for other terminal. (See IEC68-2-21/GB2423.29 Ua/Ub)	$\Delta R/R \leq 10\%$ 无机械损伤 No substantial damage
振动 vibration	根据 IEC 60738-1 频率: 10~55 Hz 振幅: 0.75 mm 方向和时间: X、Y 及 Z 轴各 2 小时 According to IEC 60738-1 Frequency: 10~55 Hz Amplitude modulation: 0.75 mm Dirction and time: X、Y and Z direction for 2 hrs each	$\Delta R/R \leq 10\%$ 无机械损伤 No substantial damage
稳态湿热放置 Damp heat, steady state	将热敏电阻放在温度 $40\pm 2^{\circ}\text{C}$ ，相对湿度 $93\pm 3\%$ 的环境中放置 1000 h（试验期间对 PTC 电阻施加一个直流电压，其值为最大电压的 $1/20$ ）。取出充分除去表面水滴，在常温下恢复 4-5h 后测试额定零功率电阻值 Ta= $40^{\circ}\text{C}$ ; R.H.= $93\pm 3\%$ ; Duration: 1000 Hr.	$\Delta R/R \leq 20\%$ 无机械损伤 No substantial damage

快速温度变化 Humidity load test	在下限温度和上限温度下，进行 50 次循环，每次循环持续时间 30 min，在常温下恢复 4-5h 后测试额定零功率电阻值  Lower limit temperature/15 min→Upper limit temperature/15 min, 50times	$\Delta R/R \leq 20\%$ 无机械损伤 No substantial damage
高温贮存试验 High temperature storage test	将热敏电阻在规定的上限类别温度环境下，放置 300h 后，在常温下恢复 4-5h 后测额定零功率电阻值  PTC shall be exposed to a temperature of Upper limit temperature for 300 hours with no loading	$\Delta R/R \leq 20\%$ 无机械损伤 No substantial damage
低温贮存试验 Low temperature storage test	将热敏电阻在规定的下限类别温度环境下，放置 240h 后，在常温下恢复 4-5h 后测额定零功率电阻值  PTC shall be exposed to a temperature of Lower limit temperature for 240 hours with no loading	$\Delta R/R \leq 20\%$ 无机械损伤 No substantial damage
室温下耐久性 Durability at room temperature	①Vrated, It<I<Imax,1min on,5min off,100 times ②Vrated, It<I<Imax,1000h	$\Delta R/R \leq 20\%$ 无机械损伤 No substantial damage
工频电流 Power frequency current	Imax, 1min on,5min off,20 times	$\Delta R/R \leq 20\%$ 无机械损伤 No substantial damage

**\*外壳型启动类产品测试 Startling casing type test**

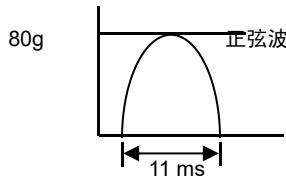
项目 Item	测试条件/测试方法 Method of test	性能要求 Specification request
引出端强度 Strength of termination	固定本体，沿端子引出方向施加 2.5 Kg 力负重 10 sec。  The body shall be fixed and the load of 2.5 Kg for 10 seconds shall be applied the terminals.	外观、结构无异常。 端子无脱落。  No remarkable Abnormality The terminals shall not be disconnected
耐振动性 Vibration test	将本体固定在安装台面上。 振幅：1.5 mm（全振幅 3.0 mm） 振动频率：10-55-10 Hz 按照每周期（10-55-10 Hz）1 分钟反复沿 X、Y、Z 三个方向各进行 1 h。  The change rate of vibration frequency shall be so selected that the frequency should increase from 10 to 55 Hz and return again to 10 Hz for 1 minute with 3.0 mm of vibration width. Such vibration cycle shall be repeated at X、Y and Z directions for each 1 hour.	电阻变化率：±20% 外观、结构无异常。  The variation ratio within resistance ±20% No remarkable abnormality
可焊性 Solderability	在助焊剂中浸 5-10 秒，然后浸入焊锡中 3±0.5 秒，检查样品焊接面。 焊锡池温度：245±5 °C 浸入深度：距样品底部 4±1 mm  Dip each terminal to flux for 5-10 s.  Then dip each terminals into 235±5 °C solder for 3±0.5 seconds .  to the 4±1 mm(pants length) above from body.	95%以上的焊接面被上焊锡  A new uniform coating solder shall cover a minimum 90% of the surface being immersed.
耐热性 Resistance to soldering heat	将焊脚浸入高温焊锡池 10±1 秒后拿出，测试电阻终值 焊锡池温度：260±5 °C 浸入深度：距样品底部 4±1 mm  Dip each terminal into 260±5 °C solder for 10±1 s to the 4±1 mm above from body	电阻变化率：±20%  The variation ratio within resistance±20%.
碰撞 Bump	按照图 4 所示方法沿 X、Y、Z、X'、Y'、Z' 6 个方向各冲击一次。 According to Fig.4 method, X、Y、Z、X'、Y'、Z',six directions,1 bumps in each direction.  <div style="text-align: center;">  </div>	电阻变化率：±20%  The variation ratio within resistance±20%.

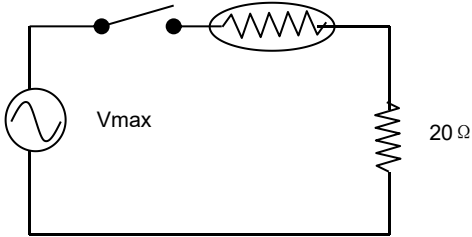

阻燃性 Flame retardant	用酒精灯火焰烘烤外壳，应无明火。 Toasting the outer with the alcohol lights flame,there should not be flame.	无明火 No flame
外观 Appearance	整体无变形，光滑平整，无破损、裂纹或划伤，标志清晰。 Have out of shape wholly,smooth to level,there are no damage,crackle or scratch,it is clear to mark.	良好 Good
常温断续负荷 ON-OFF test	<p>在常温常湿下，如图 3 电路，施加 <math>V_{max}</math> 电压，通电 1 min，断电 5 min，重复 100,000 次。试验结束后在室温 <math>25\pm 2\text{ }^{\circ}\text{C}</math> 中放置 1 小时后测量恢复阻值。</p> <p>1 minutes-ON, 5 minutes-OFF . 100,000 cycles</p> <p>After the test <math>R_{25}</math> value shall be executed after leaving specimen for 1 hour or more at room temperature at <math>25\pm 2\text{ }^{\circ}\text{C}</math>.</p>  <p style="text-align: center;">图 3 Fig.3</p>	<p>电阻变化率: <math>\pm 20\%</math></p> <p>外观、结构无异常。</p> <p>The variation ratio within resistance <math>\pm 20\%</math></p> <p>No remarkable abnormality</p>
高温连续负荷 High temperature test	<p>在 <math>85\pm 2\text{ }^{\circ}\text{C}</math> 的恒温槽中，按图 3 回路施加 <math>V_{max}</math> 电压 1000 小时后取出，在室温 <math>25\pm 2\text{ }^{\circ}\text{C}</math> 中放置 1 小时后测量恢复阻值。</p> <p>Test circuit: Fig.3</p> <p>Test temperature:<math>85\pm 2\text{ }^{\circ}\text{C}</math></p> <p>Continuous : 1000 Hrs</p> <p>After the test , <math>R_{25}</math> value shall be executed after leaving specimen for 1 hour or more at room temperature <math>25\pm 2\text{ }^{\circ}\text{C}</math>.</p>	<p>电阻变化率: <math>\pm 20\%</math></p> <p>外观、结构无异常。</p> <p>The variation ratio within resistance <math>\pm 20\%</math></p> <p>No remarkable abnormality</p>
耐湿断续负荷 ON-OFF Test(Humidity)	<p>在温度为 <math>40\pm 2\text{ }^{\circ}\text{C}</math>，湿度为 90-95%RH 的恒温槽中，按照图 3 电路，通电 30 min，断电 90 min，500 次后取出，在室温 <math>25\pm 2\text{ }^{\circ}\text{C}</math> 中放置 1 小时后测量恢复阻值。</p> <p>Test circuit: Fig.3</p> <p>Test temperature:<math>40\pm 2\text{ }^{\circ}\text{C}</math></p> <p>Test humidity:90-95%RH</p> <p>30 Min.-ON,90 Min.-OFF 500 Cycles.</p> <p>After the test, <math>R_{25}</math> value shall be executed after leaving specimen for 1 hour or more at room temperature <math>25\pm 2\text{ }^{\circ}\text{C}</math>.</p>	<p>电阻变化率: <math>\pm 20\%</math></p> <p>外观、结构无异常。</p> <p>The variation ratio within resistance <math>\pm 20\%</math></p> <p>No remarkable abnormality</p>
耐湿放置 High humidity shelf test	<p>在温度为 <math>40\pm 2\text{ }^{\circ}\text{C}</math>，湿度为 90-95%RH 的恒温槽中放置 1000 小时后取出，在室温 <math>25\pm 2\text{ }^{\circ}\text{C}</math> 中放置 1 小时后测量恢复阻值。</p> <p>Test temperature:<math>40\pm 2\text{ }^{\circ}\text{C}</math></p> <p>Test humidity:90-95%RH</p> <p>Continuous:1000 Hrs</p> <p>After the test, <math>R_{25}</math> value shall be executed after leaving specimen for 1 hour or more at room temperature <math>25\pm 2\text{ }^{\circ}\text{C}</math>.</p>	<p>电阻变化率: <math>\pm 20\%</math></p> <p>外观、结构无异常。</p> <p>The variation ratio within resistance <math>\pm 20\%</math></p> <p>No remarkable abnormality</p>

低温放置 Low temperature shelf test	在温度为 $-25\pm 5$ °C的恒温槽中放置 1000 小时后取出，在室温 $25\pm 2$ °C中放置 1 小时后测量恢复阻值。 Test temperature: $-25\pm 5$ °C Continuous:1000 Hrs After the test, $R_{25}$ value shall be executed after leaving specimen for 1 hour or more at room temperature $25\pm 2$ °C.	电阻变化率: $\pm 20\%$ 外观、结构无异常。 The variation ratio within resistance $\pm 20\%$ No remarkable abnormality															
高温放置 Low temperature shelf test	在温度为 $85\pm 5$ °C的恒温槽中放置 1000 小时后取出，在室温 $25\pm 2$ °C中放置 1 小时后测量恢复阻值。 Test temperature: $85\pm 5$ °C Continuous:1000 Hrs After the test, $R_{25}$ value shall be executed after leaving specimen for 1 hour or more at room temperature $25\pm 2$ °C.	电阻变化率: $\pm 20\%$ 外观、结构无异常。 The variation ratio within resistance $\pm 20\%$ No remarkable abnormality															
热循环 Rapid Change of Temperature	按如下条件重复 5 次，在室温 $25\pm 2$ °C中放置 1 小时后测量恢复阻值。 The conditions shown below shall be repeated 5 cycles, After the test, $R_{25}$ value shall be executed after leaving specimen for 1 hour or more at room temperature $25\pm 2$ °C. <table border="1" data-bbox="405 904 1050 1182"> <thead> <tr> <th>步骤 Step</th> <th>温度 Temperature (°C)</th> <th>时间 Period (min)</th> </tr> </thead> <tbody> <tr> <td>1</td> <td><math>-25 \pm 5</math></td> <td><math>30 \pm 3</math></td> </tr> <tr> <td>2</td> <td>室温 Room temperature</td> <td><math>5 \pm 3</math></td> </tr> <tr> <td>3</td> <td><math>85 \pm 5</math></td> <td><math>30 \pm 3</math></td> </tr> <tr> <td>4</td> <td>室温 Room temperature</td> <td><math>5 \pm 3</math></td> </tr> </tbody> </table>	步骤 Step	温度 Temperature (°C)	时间 Period (min)	1	$-25 \pm 5$	$30 \pm 3$	2	室温 Room temperature	$5 \pm 3$	3	$85 \pm 5$	$30 \pm 3$	4	室温 Room temperature	$5 \pm 3$	电阻变化率: $\pm 20\%$ 外观、结构无异常。 The variation ratio within resistance $\pm 20\%$ No remarkable abnormality
步骤 Step	温度 Temperature (°C)	时间 Period (min)															
1	$-25 \pm 5$	$30 \pm 3$															
2	室温 Room temperature	$5 \pm 3$															
3	$85 \pm 5$	$30 \pm 3$															
4	室温 Room temperature	$5 \pm 3$															

◆电阻-温度特性曲线图 R-T Characteristic Curves

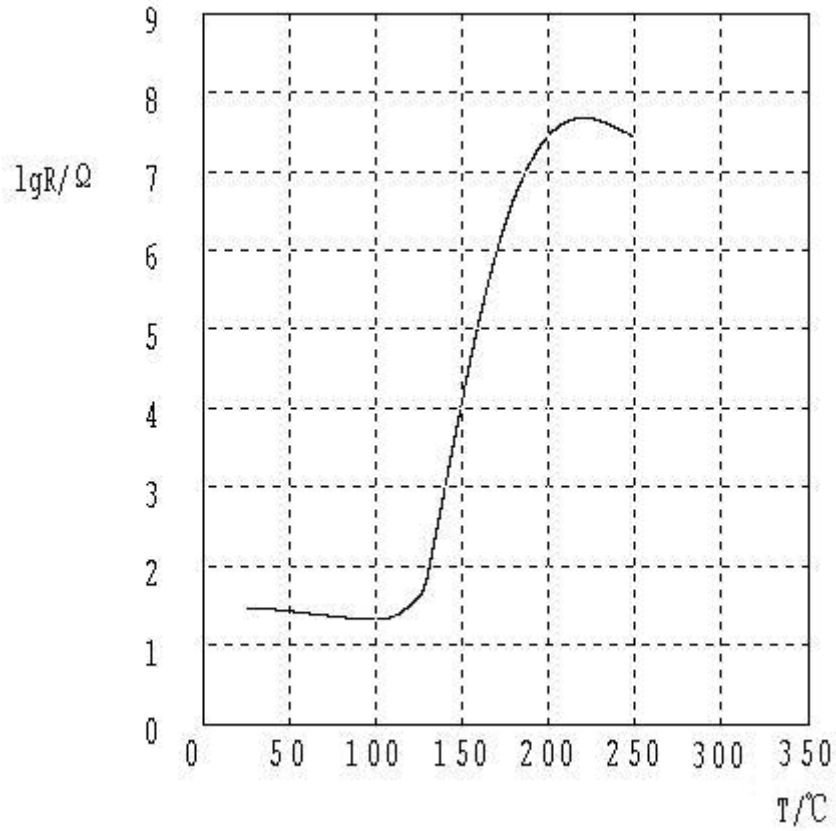

参考曲线 Curve of reference

◆V-I 曲线 V-I Curve

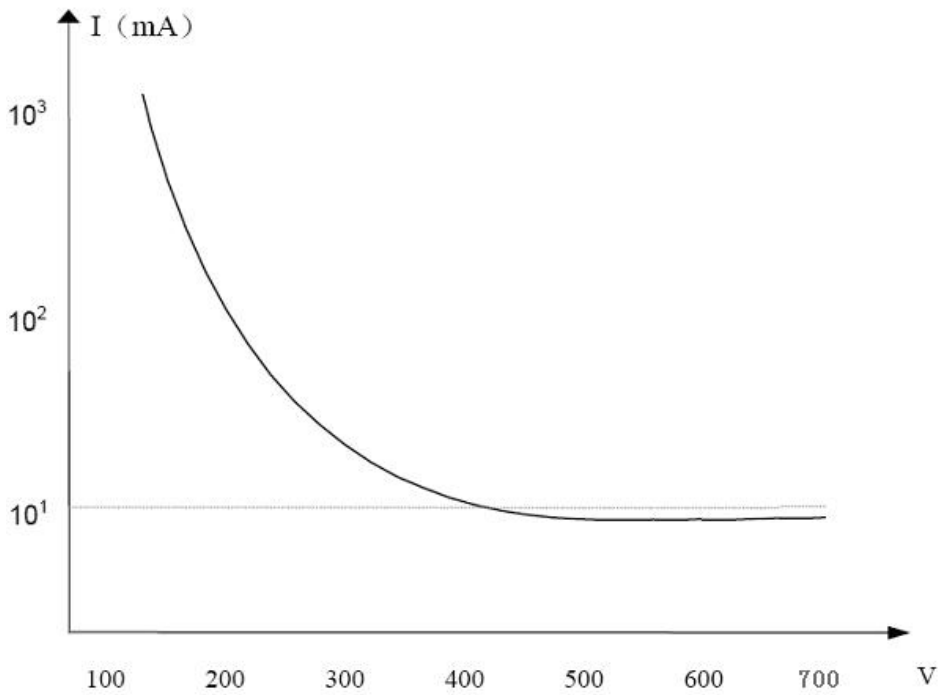

参考曲线 Curve of reference

**◆包装 Packaging**
**\* 散装 Bulk**

型号 model	数量 Quantity	
	散装/塑料袋 Bulk / Plastic bag	
	长脚 Long Lead	短脚 Short Lead
Φ5	1000pcs	1000pcs
Φ7、Φ8	1000pcs	1000pcs
Φ9、Φ10	500pcs	1000pcs
Φ12	500pcs	500pcs
Φ14	500pcs	500pcs
Φ16	300pcs	500pcs
Φ20	200pcs	200pcs
个别型号有特殊包装数量 Special package quantity for individual models		

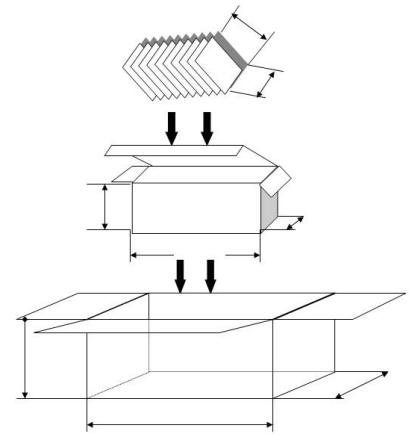
**\* 编带 Tape**

型号 model	数量 Quantity
	编带/盒装 Tape / Paper Box
Φ5、Φ7、Φ8、Φ9、Φ10	1000PCS
Φ12、Φ14	800PCS
Φ16、Φ20	500PCS
个别型号有特殊包装数量 Special package quantity for individual models	

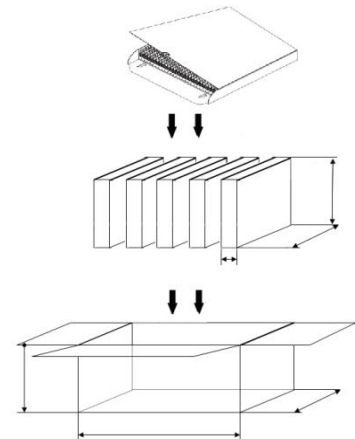

**◆环保情况说明 Environmental Protection Statement**

\* 我司提供的所有热敏电阻物料均符合 ROHS+无卤要求及 Reach 法规要求，请贵司放心使用。

We provide all thermistor materials conform to the requirements of ROHS directive, Halogen Free and the Reach regulation, please rest assured to use.

### ◆ 推荐焊接条件 Soldering Recommendation

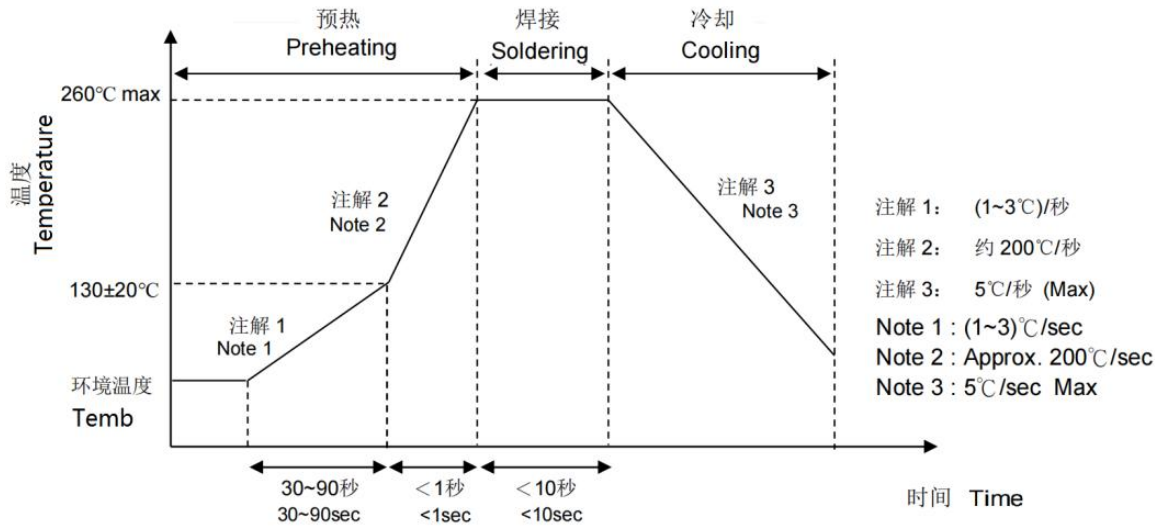
\* 波峰焊曲线 Wave soldering profile



\* 手工焊接 Iron soldering

项目 Item	条件 Conditions
烙铁头温度 Temperature of soldering Iron-tip	360°C (max.)
焊接时间 Soldering Time	3s (max.)
焊接位置与涂装层距离 Distance from Varistor	2mm (min.)

### ◆ 贮存方法 Storage Methods

\* 元器件必须储存在清洁、通风、无腐蚀性气体的仓库内；除另有规定外，仓库的温度和相对湿度必须满足如下要求：a.温度：5~30℃；b.相对湿度：20%~75%；存储期限：1年。

Components must be stored in a clean, ventilated, non-corrosive gases warehouse; Unless otherwise specified, the warehouse temperature and relative humidity must meet the following requirements: a. Temperature: 5 ~ 30 °C; b. Relative humidity: 20% ~ 75%; Period of Storage: 1 year.

### ◆使用注意事项 Precautions For Use

\*为避免引起 PTC 热敏电阻性能劣化与元件破坏、冒烟、起火等现象，请严守下列事项：

Please do not expose posistor to any abnormal environment. Or it may deteriorate posistor's character, worsely, may cause malfunction (or damage).

\*使用时请不要超过最大使用电压；

Please use posistor within the specified maximum voltage and at higher coil resistance as specified

\*使用时请不要超过最大突入电流；

Please use posistor within the specified maximum current

\*请在规定的温度使用范围以内使用；

Please be sure to use posistor at proper range of temperature

\*由于 PTC 热敏电阻发热温度可能去到 100℃ 到 160℃，使周围的部件、材料受到热影响，请确认不要造成劣化与损伤。特别对于供电部位（引出端子与基板等），因为温升高，请在设计时考虑其耐热性；

When this product is operated, temperature of some area may be over 100℃ to 160℃. Please make sure that surrounding parts and inserting material can withstand the temperature. If the surrounding part and materials is kept under such condition, they may be deteriorated or may produce harmful gas(Cl<sub>2</sub>, H<sub>2</sub>S, NH<sub>3</sub>, Sox, NO<sub>x</sub> etc.).And, such harmful gas may deteriorate the element.

\*PTC 热敏电阻没有防水结构、耐药品结构及耐溶剂结构，请不要沾水，也不要沾染压缩机油、药品及溶剂；

This product does not have waterproof construction. A splashed water may cause failure mode such as decline of characteristic or current leak.

\*请不要超过规定的振动、冲击（落下等）与压力；

The ceramic element of this product is fragile, and care must be taken not to load a excessive pressforce or not to give a shock at handling. Such forces may cause cracking or chipping.

\*规定保管场所的温度为-10℃~+40℃，相对湿度为 75%RH 以下，并且要避免急剧的温度变化、直射阳光，避免腐蚀性气体、灰尘、尘土的气氛；不要施加过重的压力，使包装状态保持原样；

Please store posistor under following conditions, without breaking package

Storage temperature :between-10℃ and 40℃

Storage humidity: less than 75%RH (no dew)

Storage place :keep away from sun, any halogen gas ,such as chorine or sulfurous Materials

\*请不要在下列环境下使用：

Please do keep Posistor away:

①腐蚀性气体（Cl<sub>2</sub>、NH<sub>3</sub>、SO<sub>x</sub>、NO<sub>x</sub> 等）；②具有挥发性、易燃性气体的气氛；③置于有水、盐水、油渍等地方；④真空中、减压中、加压中；⑤粉尘多的地方；⑥振动多的地方。

①From caustic and reductive gas (such as Cl<sub>2</sub>, H<sub>2</sub>S, NH<sub>3</sub>, SO<sub>x</sub>, NO<sub>x</sub> etc.)

②From volatile and combustible gas.

③From water salt solution, oil, lotion and organic solvent

④From reducing or compressing atmosphere.

⑤From dusty place

⑥From violent vibration

\*PTC 热敏电阻是依照指定的用途而综合设计的，请不要在指定的用途以外使用。

You are requested not to use our product deviating from the agreed specifications.

\*请在电路设计时安装 PTC 热敏电阻以后，必须进行可靠性评价试验，以确认 PTC 热敏电阻无异常。

Please make sure that your product has been evaluated in view of your specifications with our product being mounted to your product